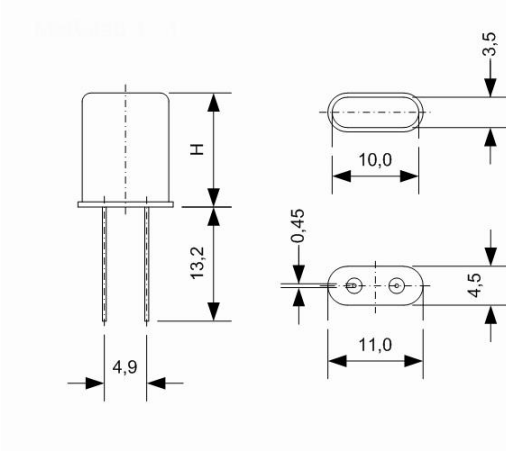

Table 1

ENCLOSURE	H [mm]	CODE	
HC-49/U	13.2	20	
	10.6	21	starting with 4 MHz
	9.2	22	starting with 10 MHz



Metal Housing: Resistance Weld
Inert gas N₂/He
Laser engraving

Table 2

1.8 ... 250 MHz		Unit	Condition
Frequency range	1.8 - 250	MHz	
Crystal cut	AT		
Enclosure	HC-49/U		
Mode	1. 1.8 - 40 3. 15 - 100 5. 45 - 160 7. 100 - 210 9. 140 - 250	MHz MHz MHz MHz MHz	Fundamental 3 rd overtone 5 th overtone 7 th overtone 9 th overtone
Load capacitance	10 – 60pF or Series	pF	
Shunt capacitance	1.8 - 4.0 MHz: < 3.0 pF 4.0 - 10 MHz: < 5.0 pF 10 - 250 MHz: < 7.0 pF	pF	
Motional capacitance			
Resistance R _R			see table 5
Frequency adjustment			see table 3
Nominal temperature and temp. stability			see table 4
Aging 1 st year	< 2.0 – 3.0	ppm	
Shock	100 g / 6 ms		
Vibration	10 g _{SS} / 1.5 mm _{SS} 50 – 500 Hz		
Δf / f	< 5.0	ppm	
ΔR / R	< 20 %		

Table 3

FREQUENCY ADJUSTMENT NOMINAL TEMPERATURE	FREQUENCY [MHz]					Code
	1.8 ... 40	15 ... 100	45 ... 160	100 ... 210	140 ... 250	
Mode	1	3	5	7	9	
Frequency adjustment / ppm	± 3	± 3	± 3			C1
	± 5	± 5	± 5	± 5	± 5	E1
	± 10	± 10	± 10	± 10	± 10	J1
	± 20	± 20	± 20	± 20	± 20	B2
	± 50	± 50	± 50	± 50	± 50	H2

Table 4

NOMINAL TEMPERATURE AND TEMPERATURE TOLERANCE			
Temperature	Code	Temperature tolerance	Code
+ 40°C	40	± 3	C
+ 50°C	50	± 5	E
+ 55°C	55		
+ 60°C	60		
+ 65°C	65		
+ 70°C	70		
+ 75°C	75		
+ 80°C	80		
+ 85°C	85		
+ 90°C	90		
+ 95 °C	95		

Table 5

MAX. RESISTANCE R _R	MODE	FREQUENCY [MHz]	R _{RMAX} [Ω]
	1	1.8 - 2.0	500
		2.0 - 3.0	300
		3.0 - 5.0	120
		5.0 - 12	40
		12 - 40	15
	3	10 - 20	30
		20 - 100	22
	5	45 - 55	70
		55 - 160	50
	7	100 - 210	100
	9	140 - 250	180

Table 6

Odering Code ⁽¹⁾	FREQUENCY [MHz]	ENCLOSURE CODE: TABLE 1	MODE: 1: FUND. 3,5,7,9: OT TABLE 2	LOAD CAP.: 00: SERIES 32: 32 pF TABLE 2	ADJ. Tolerance CODE: TABLE 3	NOMINAL TEMPERATURE CODE: TABLE 4	SHUNT CAPACITANCE 25: 2.5 pF TABLE 2
	12.8	20	1	32	J1	70C	25

⁽¹⁾ Other specifications on request

