



Features

- Low frequency in small size SMD
- Seam sealed ceramic package offers excellent environmental & heat resistance
- Extended temperature -40°C to +85°C for industrial applications

Applications

- Commercial and Industrial applications
- Wireless communications
- PDA and Smartphone
- Time of day applications

General Specifications

Nominal Frequency	32.768kHz
Frequency Tolerance at 25°C	±20ppm
Temperature Coefficient	-0.034 ± 0.008ppm/Δ °C ²
Temperature Range (Operating)	-40 to +85°C
Storage Temperature	-55 to +125°C
Load Capacitance C _L	6pF, 7pF, 9pF, 12.5pF
Shunt Capacitance C ₀	1.7pF typ.
Motional Capacitance C ₁	3.0fF typ.
Equivalent Series Resistance (ESR)	65KΩ max.
Drive Level	1μW max.
Aging per Year	±3ppm max.
Insulation Resistance (M.Ω)	500 at 100Vdc ±15Vdc
Quality Factor	70000 typ.
Capacitance Ratio	450 typ.

Mechanical Dimensions

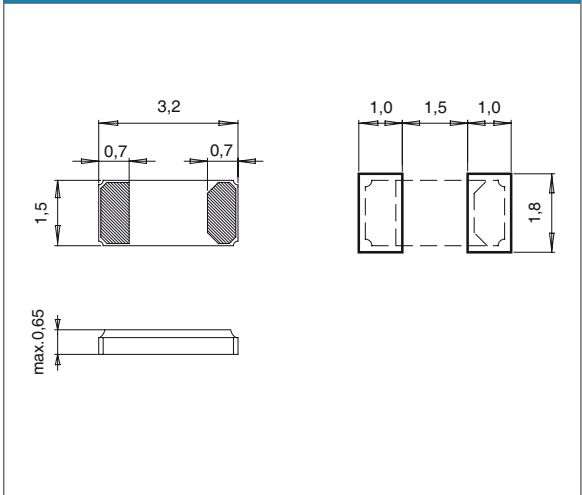

Part Numbering Guide

QT Code	Package	Nominal Frequency (in kHz)	Load Capacitance	Operating Temperature Range	Frequency Tolerance	Packaging
QT = Quartz-technik	TC3 = 1.5x3.2 SMD Tuning Fork	32.768	06 = 6pF 07 = 7pF 09 = 9pF 12 = 12.5pF	B = -40 to +85°C	1 = ±10ppm 2 = ±20ppm 3 = ±30ppm	R = 3000pcs Tape&Reel

Example: QTTC332.76812B2R

bold letters = recommended standard specification

Tape and Reel Dimensions

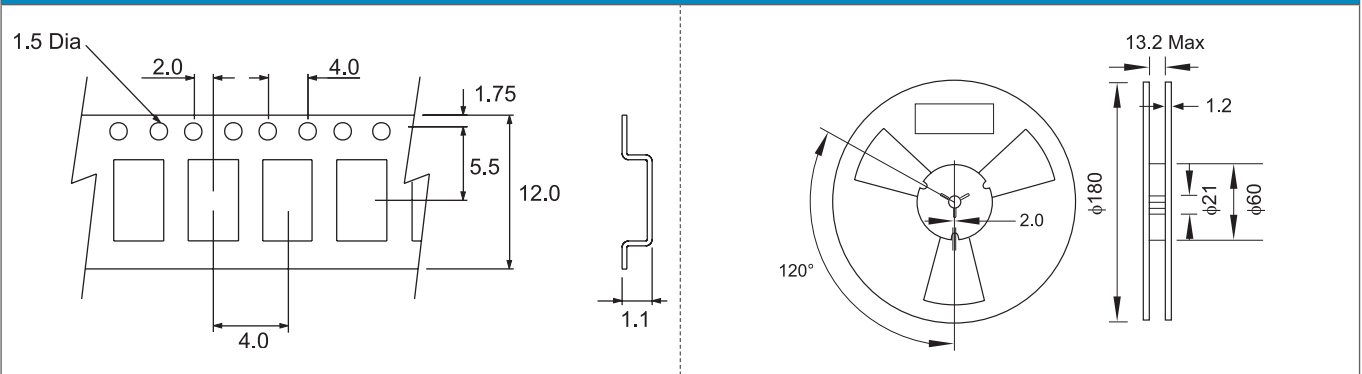

Quarztechnik Daun GmbH

Quartz Crystals • Oscillators • Sensor Technology

Alte Darscheider Strasse 15
54550 Daun • Germany

Phone: +49 0 6592-92070
Fax: +49 0 6592-7670

info@quarztechnik.com
www.quarztechnik.com



Marking Code Guide

Contains manufacturer code / lot code

Solder Reflow Profile

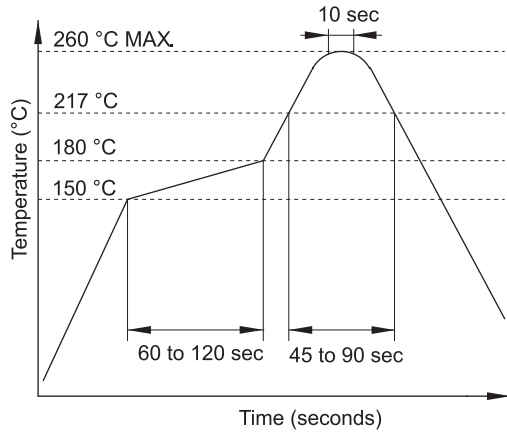

Frequency vs. Temperature Characteristics

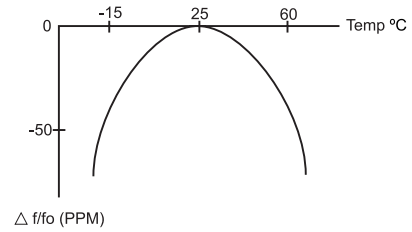

To calculate the frequency stability the parabolic curvature constant (K) is needed.

For calculating the stability at 45°C?

1- Change in temperature (ΔT) is (45-25) = +20°C

2- Change in frequency is $(-0.034 \times (\Delta^{\circ}\text{C})^2) = (-0.035 \times (20)^2) = -13.6\text{ppm}$



Quarztechnik Daun GmbH

Quartz Crystals • Oscillators • Sensor Technology

Alte Darscheider Strasse 15
54550 Daun • Germany

Phone: +49 0 6592-92070
Fax: +49 0 6592-7670

info@quarztechnik.com
www.quarztechnik.com

